

# DTS(G)L-6, DTS(G)F-6 SERIES

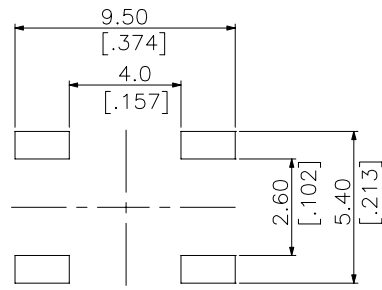

## DIMENSIONS

### DTSF-6

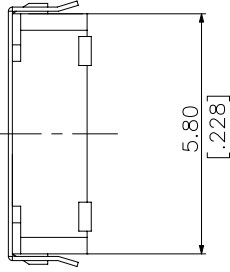
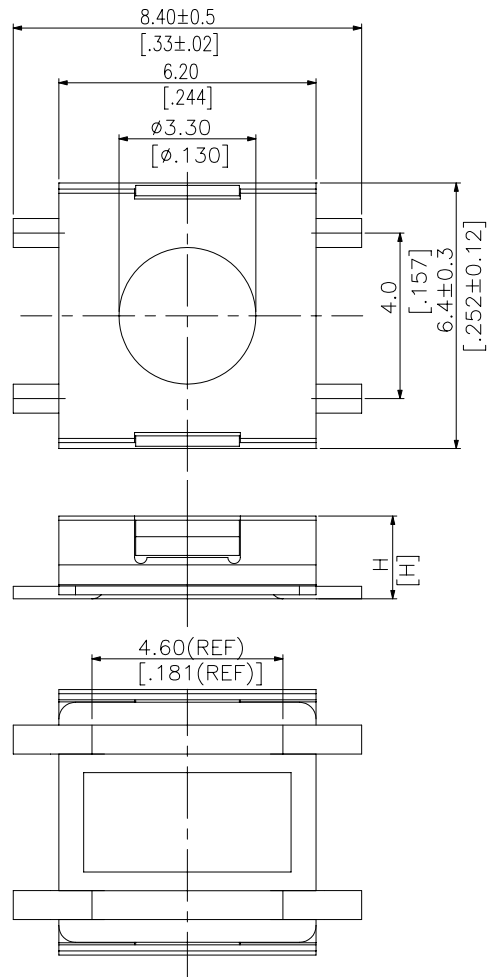

P.C.B. LAYOUT

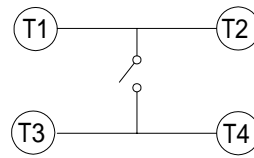

CIRCUIT DIAGRAM

DTSF-62	3.1 ( .122 )
DTSF-61	2.5 ( .098 )
DTSF-60	2.0 ( .079 )
PART NO.	H

### DTSGF-6

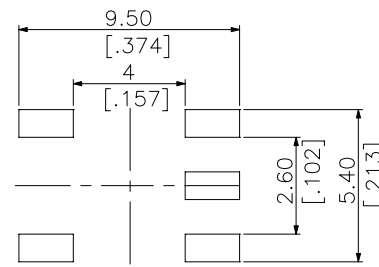
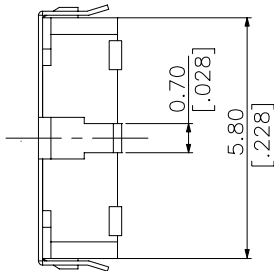
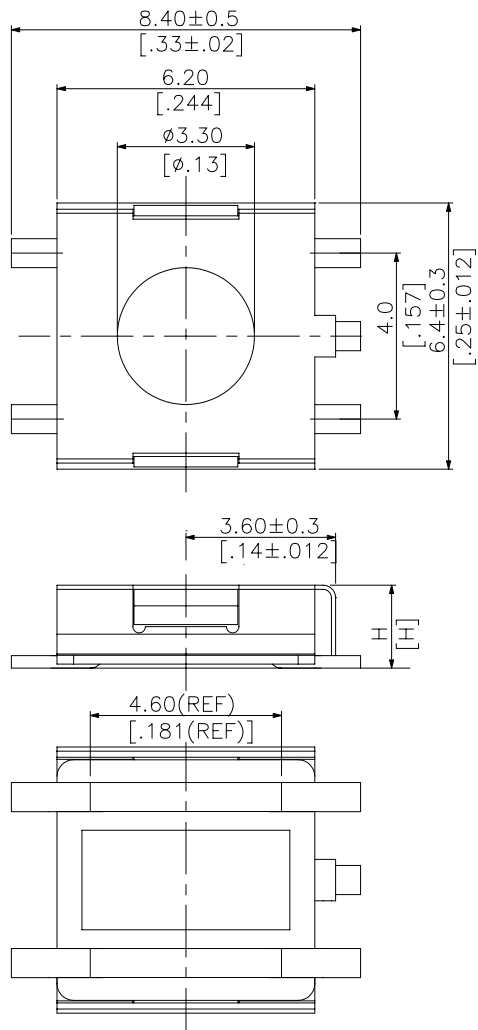

P.C.B. LAYOUT

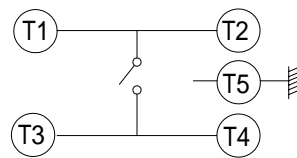

CIRCUIT DIAGRAM

DTSGF-62	3.1 ( .122 )
DTSGF-61	2.5 ( .098 )
DTSGF-60	2.0 ( .079 )
PART NO.	H

**DTSL-6**

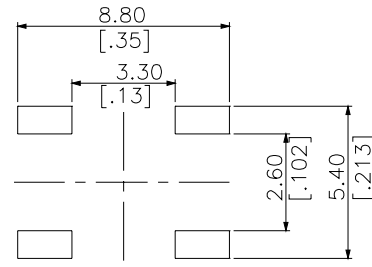
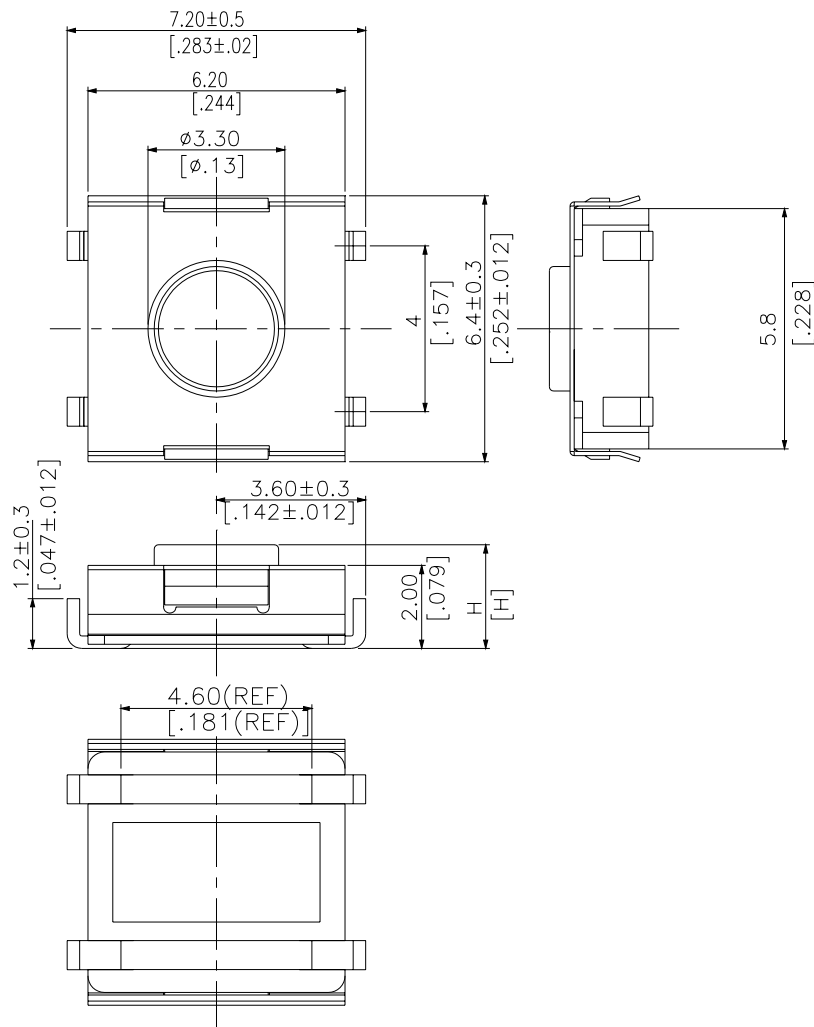

*P.C.B. LAYOUT*

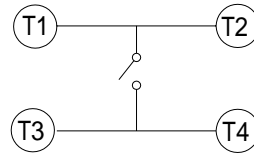

*CIRCUIT DIAGRAM*

DTSL-62	3.1 (.122)
DTSL-61	2.5 (.098)
DTSL-60	2.0 (.079)
PART NO.	H

**DTSG-6**

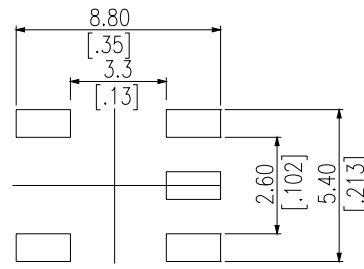
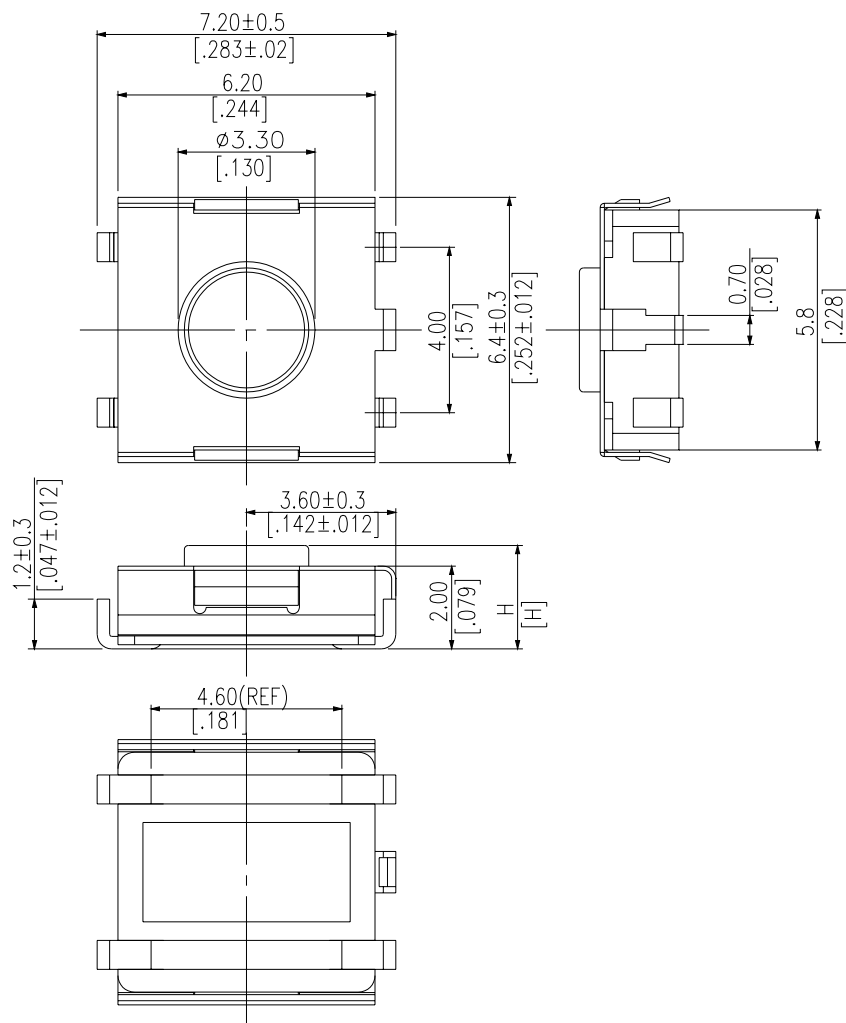

*P.C.B. LAYOUT*

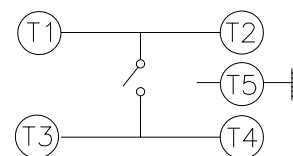

*CIRCUIT DIAGRAM*

DTSG-62	3.1 (.122)
DTSG-61	2.5 (.098)
DTSG-60	2.0 (.079)
PART NO.	H

## HOW TO ORDER

DTS

- 6

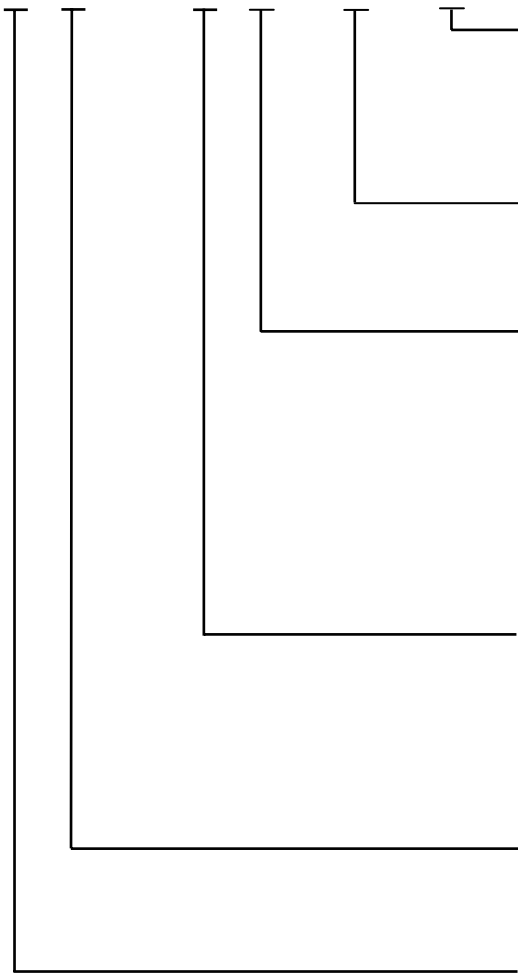

Package Style:

B = Tube

T/R = Tape & Reel

Soldering:

V = Lead Free Solderable

Color of Stem for Operation Force:

K = Black, 100gf

N = Brown, 160gf, 180gf

R = Red, 260gf

S = White, 320gf

Y = Yellow, 520gf

\*N = Brown, 200g [TACT 3.1 ONLY]

Height:

0 = 2.0mm

1 = 2.5mm

2 = 3.1mm (200gf only)

L = With L S.M.T Terminal

F = With F S.M.T Terminal

Product Series:

G = With Ground Terminal

= Without Ground Terminal

## SPECIFICATION

### MECHANICAL

Operation Force: 100±50gf Black(K)  
 160±50gf Brown(N)  
 260±50gf Red(R)  
 320±80gf White(S)  
 520±130gf Yellow(Y)

Stroke: 0.25+0.2/-0.1mm

Operation Temperature: -25 to +70

Storage Temperature: -30 to +80

### ELECTRICAL

Electrical Life: 100,000 cycles for 320gf,520gf  
 100,000 cycles for 260gf  
 200,000 cycles for 100gf,160gf,180gf

Rating : 50 mA , 12 VDC

Contact Resistance : 100mΩ max

Insulation Resistance : 100MΩ min , at 500 VDC

Dielectric Strength : 250 VAC / 1minute

Contact Arrangement : 1 pole 1 throw

## MATERIALS

COVER: Stainless steel ( DTSL.F-6 )

Nickel Silver ( DTSG.L.F-6 )

BASE: UL 94V-0 Nylon High-temp thermoplastic

Color: Black

CONTACT DISC: phosphor bronze with silver cladding

TERMINAL: Brass with silver plated

STEM : UL94V-0 Nylon High-temp Thermoplastic

Color : Black(100gf) , Brown(160gf) , Red(260gf) ,  
 White(320gf) , Yellow(520gf)

Silicon Rubber Color : Brown (200gf)

## LEAD-FREE SOLDERING CONDITIONS

**HAND SOLDERING** : Use a soldering iron of 30 watts, controlled at 350 approximately max 5 seconds while applying solder.

**REFLOW SOLDERING** : When applying reflow Soldering , the peak temperature or the reflow oven should be set to 260 max. Condition for soldering. ( Reflow & Non-washable type )

Temperature Profile :

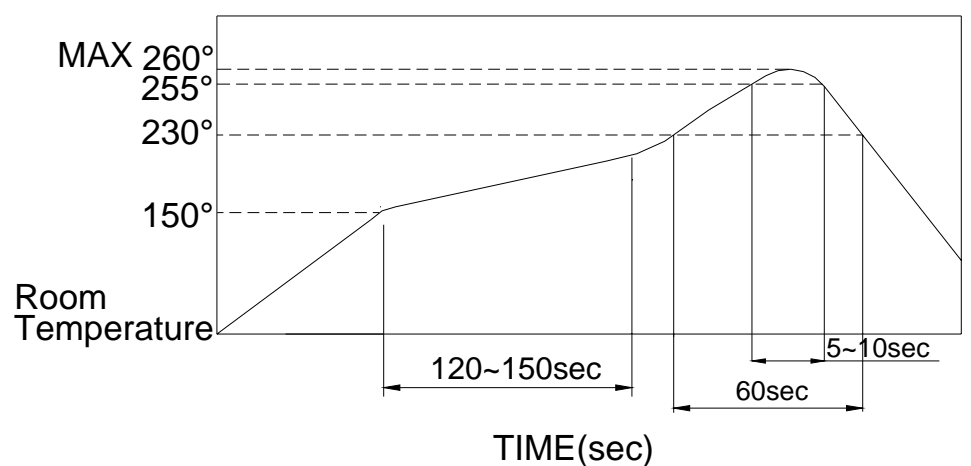

# PACKING

Part Number	Number Per Tube	Number Per Reel
DTS(G)L-60(1)	75	2700
DTS(G)F-60(1)	75	3000
DTS(G)L-62	75	2500
DTS(G)F-62	75	2500

## DTS(G)L, F-62 reel

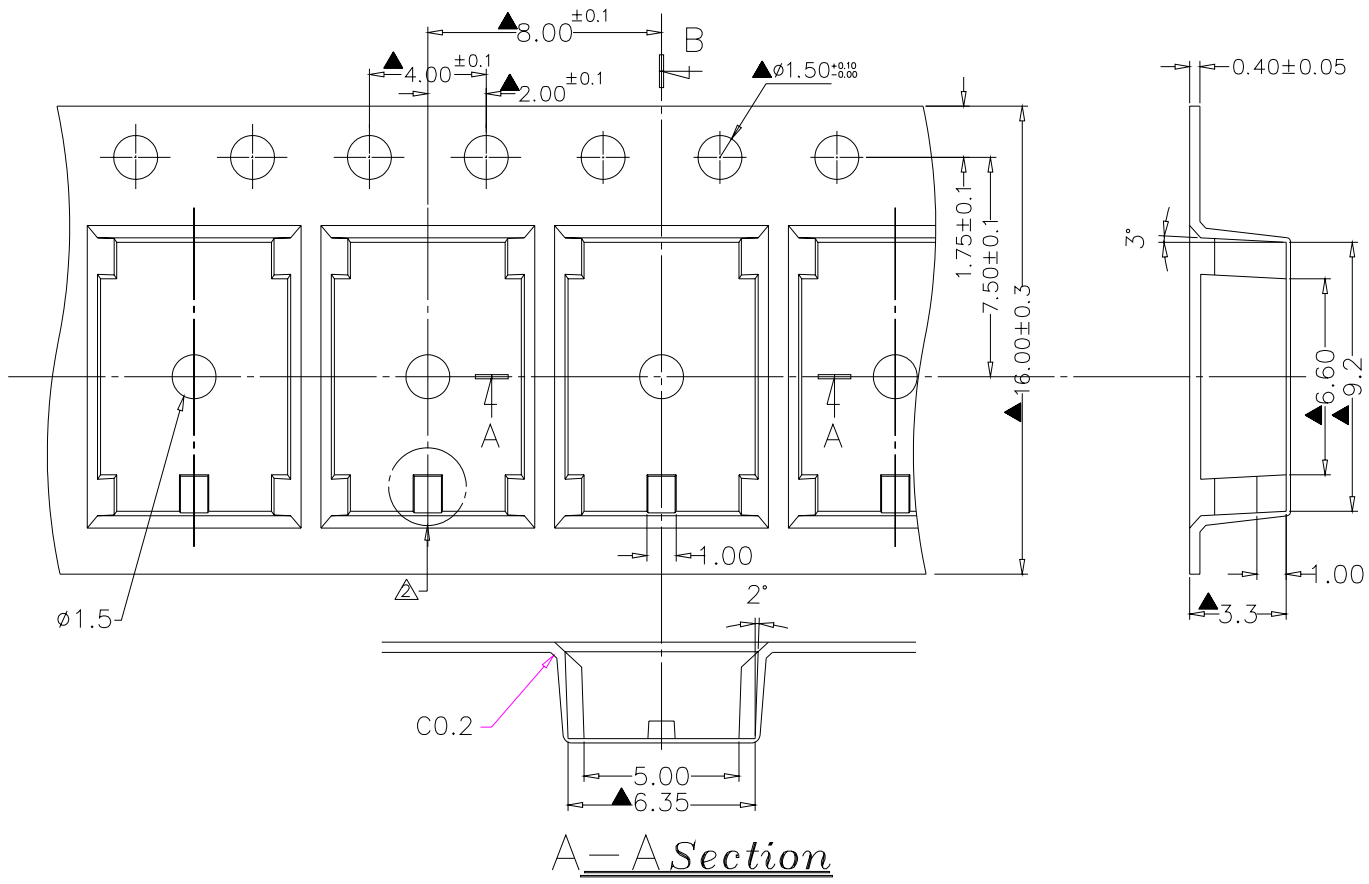

## DTS(G)L, F-60, 61 Reel

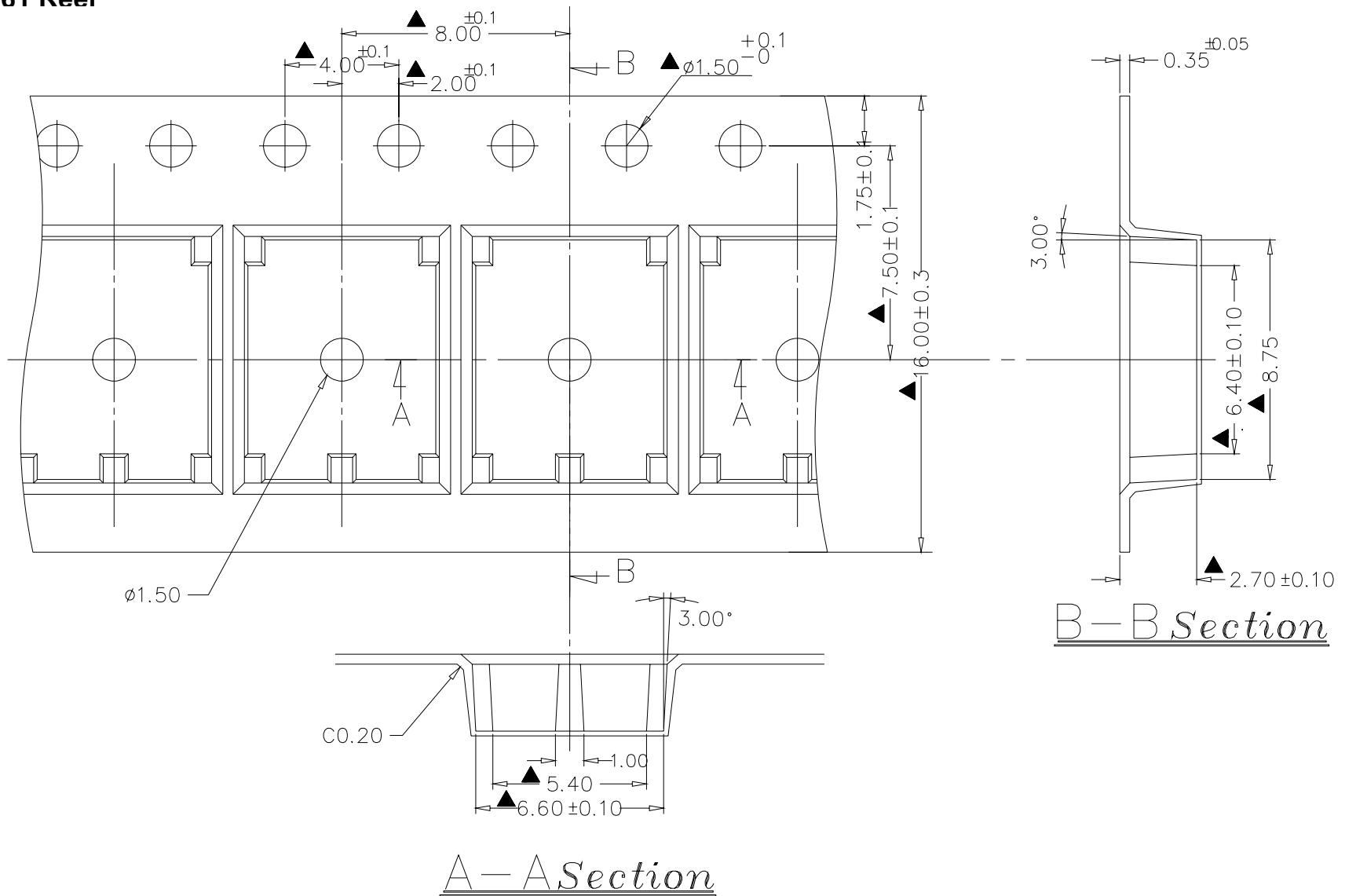

DTS(G)L-6 TUBE

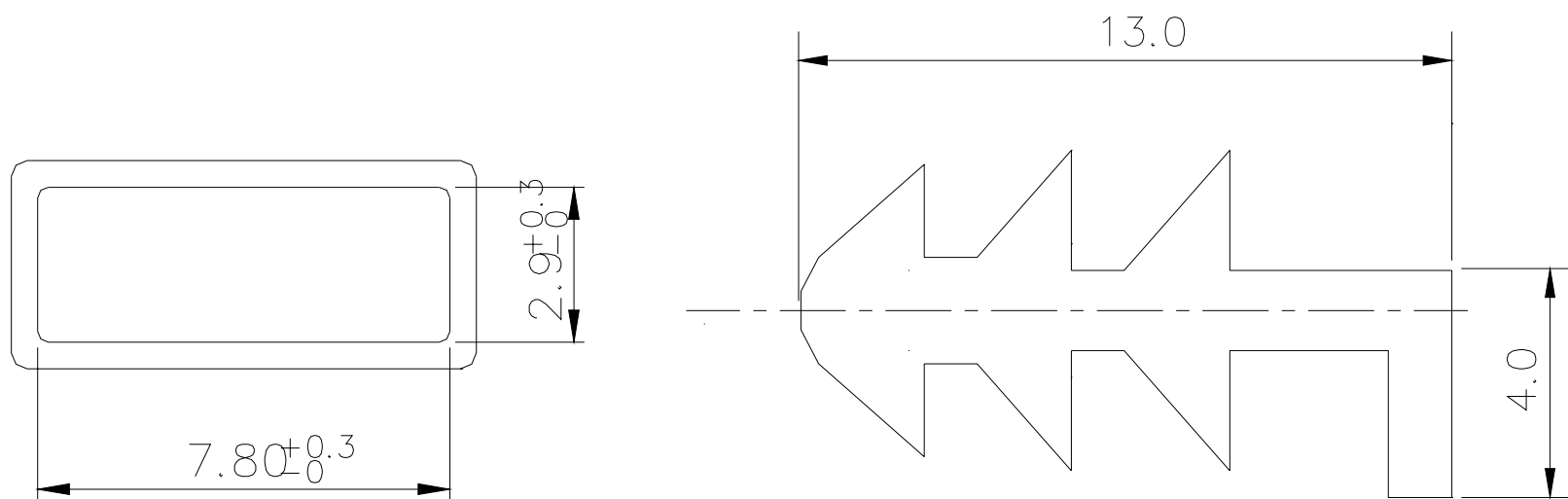

DTSF-60、61 TUBE

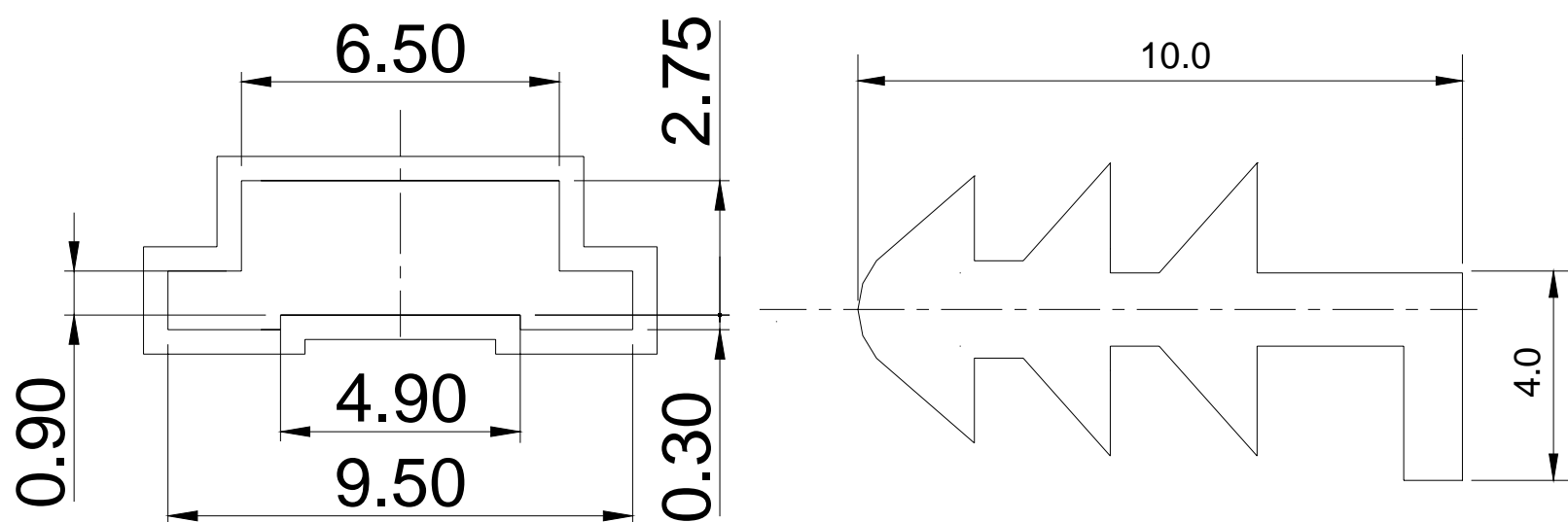

DTSGF-60、61 TUBE

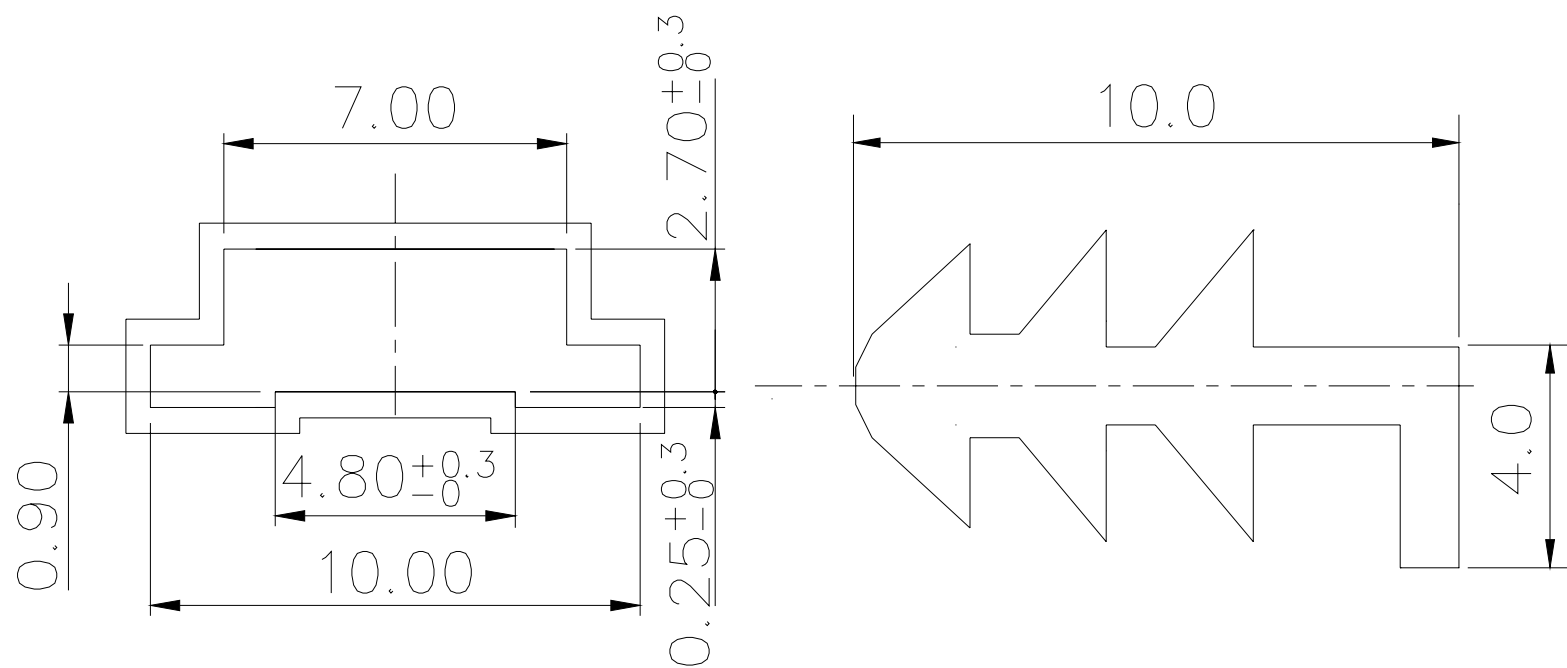

DTS(G)F-62 TUBE

