

DTST-6 SERIES

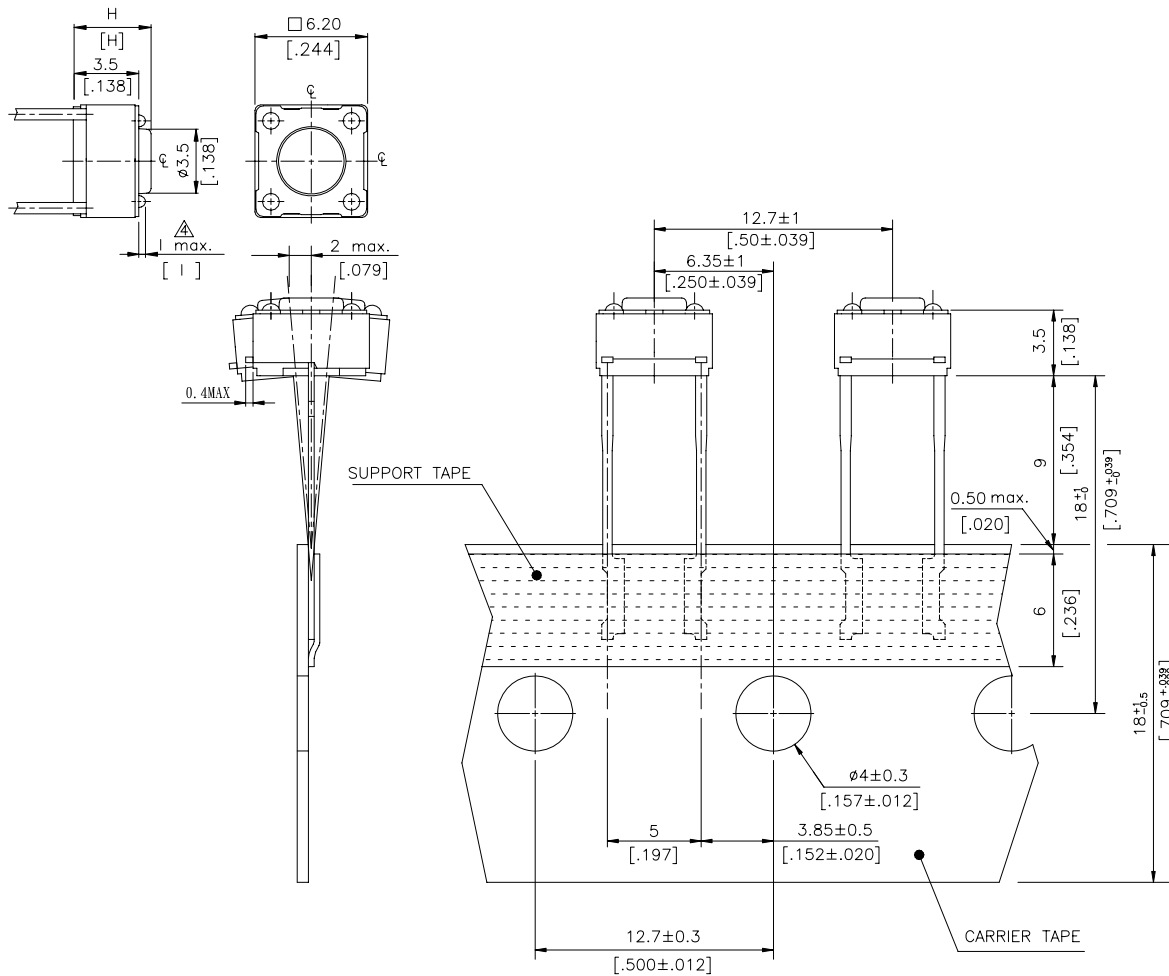

DIMENSIONS

DTST-6



DTST-62~66 □	0.6 MAX	.0236 MAX
DTST-61 □	0.5 MAX	.0197 MAX
PROD.	NO.	I
		INCHES.

DTST-66 □	13.0	[.512]
DTST-65 □	9.5	[.374]
DTST-63 □	7.0	[.275]
DTST-62 □	5.0	[.197]
DTST-61 □	4.3	[.169]
PROD.	NO.	H

****GENERAL TOLERANCES MAX:±0.2mm.****

DTST-64(8)

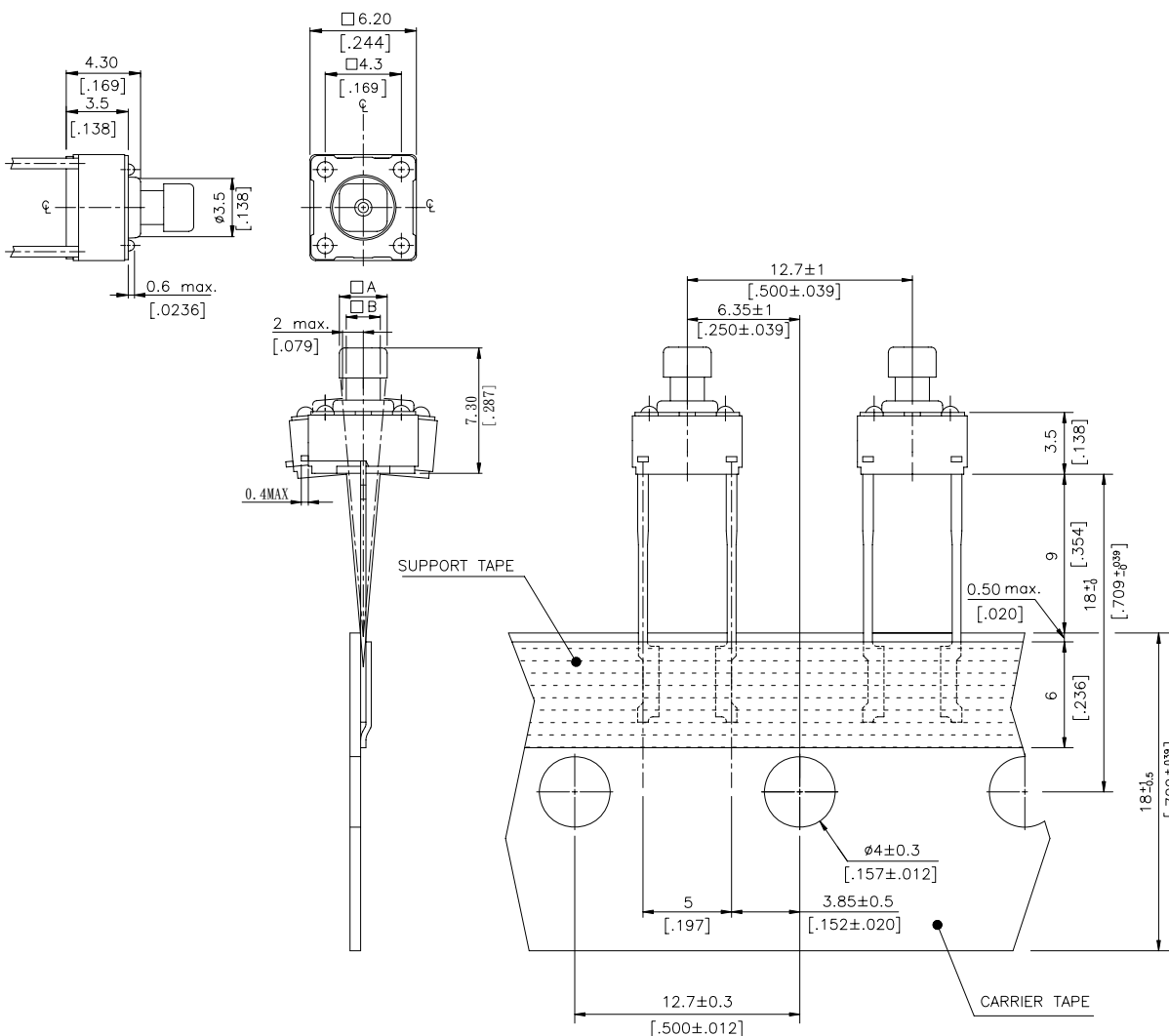

DTST-644	□ A	2.4	.095	
	□ B	1.6	.063	
DTST-648(□ A	2.8	.11	
	□ B	2.0	.079	
PROD.	NO.	LOC.	MM.	INCH.

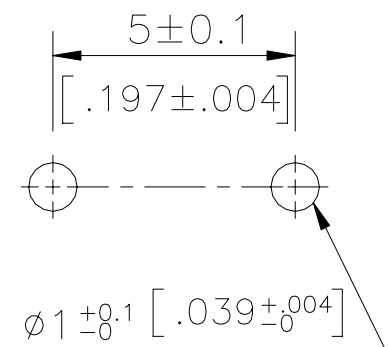

P.C.B LAYOUT

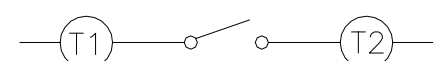

CIRCUIT DIAGRAM

****GENERAL TOLERANCES MAX:±0.2mm.****

HOW TO ORDER

DTST - 6 □ □ □ - □

Soldering
V=Lead Free Solderable

Color of Stem For Operating Force:

K = Black, 100gf
N = Brown, 160gf
R = Red, 260gf
S = Salmon, 320gf
Y = Yellow, 520gf

Dimension H:

1 = 4.3mm
2 = 5.0mm
3 = 7.0mm
44 = 7.3mm (SQ.) x 2.4mm
48 = 7.3mm (SQ.) x 2.8mm
5 = 9.5mm
6 = 13mm

Radial Taping Type Tactile Switch

SPECIFICATION

△MECHANICAL

Operation Force: 520 ± 130gf Yellow (Y)
320 ± 80gf Salmon (S)
260 ± 50gf Red (R)
160 ± 50gf Brown (N)
100 ± 50gf Black (K)

Stop Strength: Max.3kgf vertical static load continuously for 15 seconds.

Stroke: (6x6) 0.25 + 0.2mm / - 0.1mm

Operation Temperature: -25°C to +70°C

Storage Temperature: -30°C to +80°C

△ELECTRICAL

Electrical Life: 300,000 cycles for 320gf, 520gf
500,000 cycles for 260gf
1,000,000 cycles for 100gf, 160gf

Rating: 50mA , 12VDC

Contact Resistance: 100mΩ max.

Insulation Resistance: 100MΩ min. at 500VDC

Dielectric Strength: 250VAC/ minute

Contact Arrangement: 1 pole 1 throw

MATERIALS

△COVER: Steel

△BASE: UL94V-0 Nylon Thermoplastic.
Color: Black

△STEM: UL94V-0 Nylon Thermoplastic
Color: Black (100gf), Brown (160gf)
Red (260gf), Salmon (320gf)
Yellow (520gf)

△CONTACT DISC: Phosphor bronze with silver cladding

△TERMINAL: Brass with silver Plated

SOLDERING PROCESS

△WAVE SOLDERING : Recommended solder temperature at 500°F(260°C) max. 5 seconds.

△HAND SOLDERING : Use a soldering iron of 30 watts, controlled at 350°C approximately max 5 seconds while applying solder.

PACKING

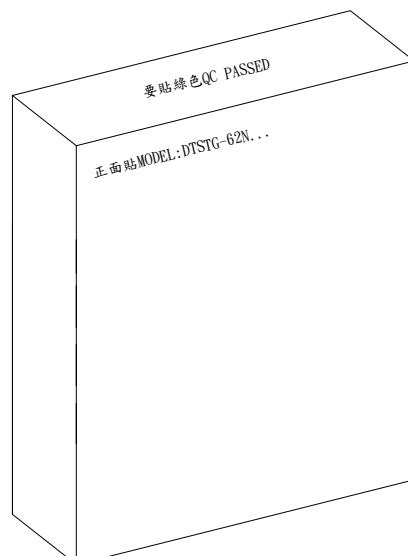
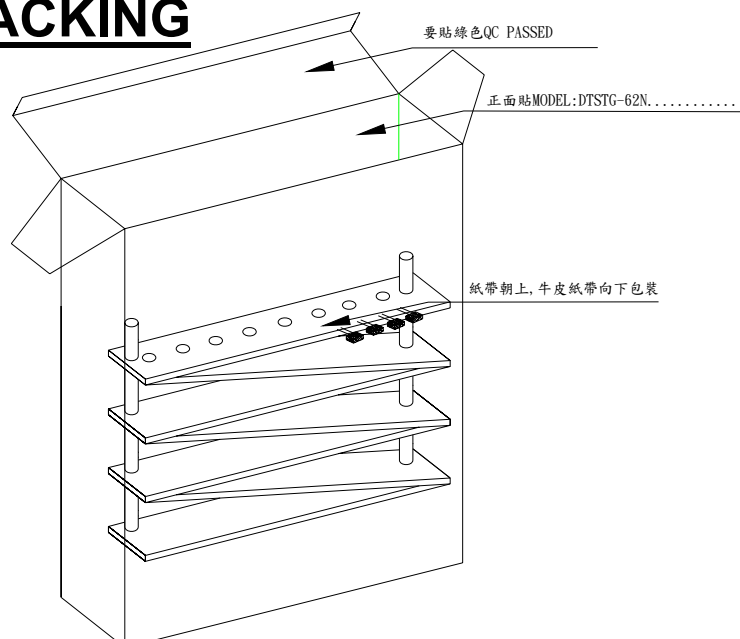

Part Number	Number Per Box	
DTST-6	900	