

TAC-3 & TA(N)2-3 SERIES

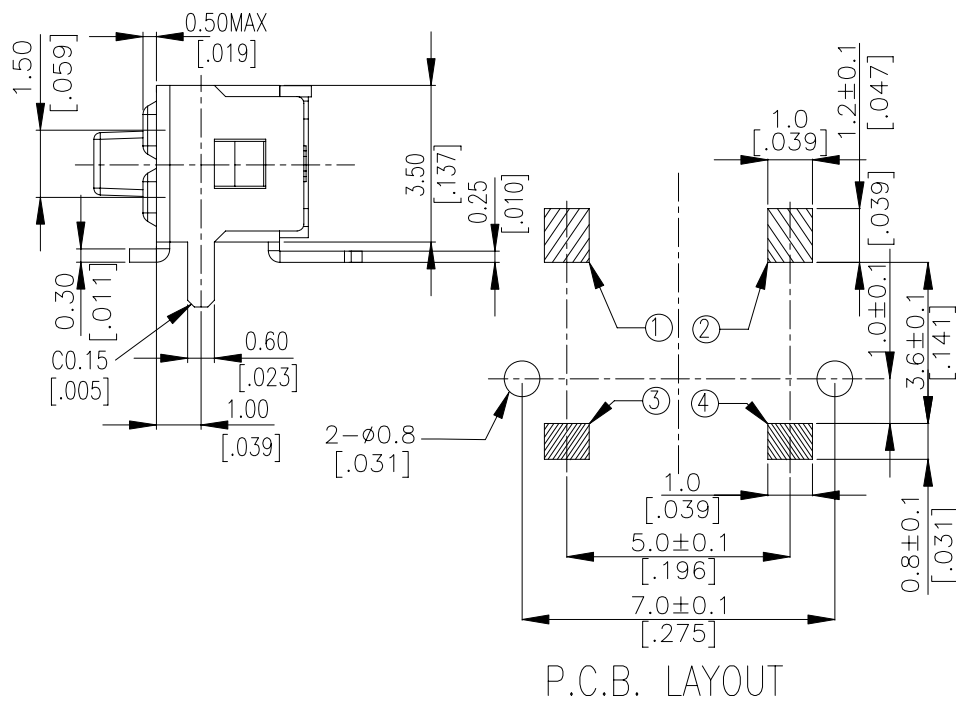

DIMENSIONS

TAC-3

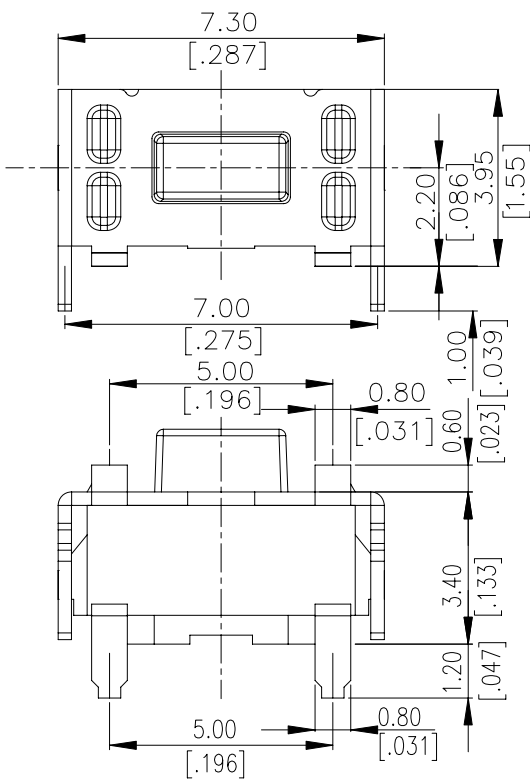
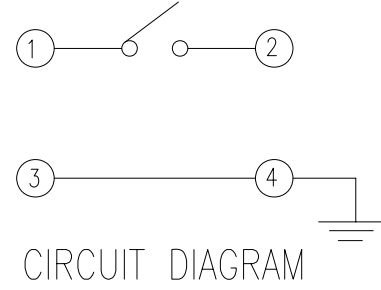
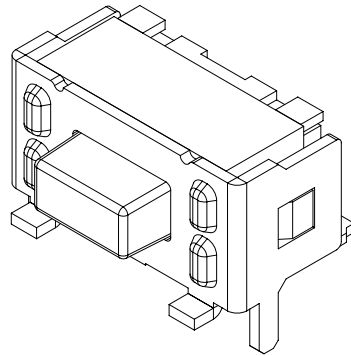

TACN2-3

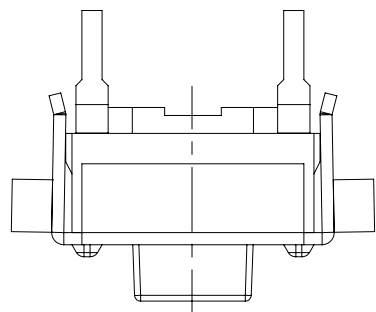

CIRCUIT DIAGRAM

附表一

TAN2-32	1.4 [.055]	S SALMON 320g W WHITE 160g
TAN2-31	0.7 [.028]	S SALMON 320g W WHITE 160g
PART NAME:	L	COLOR FOR OPERATING FORCE

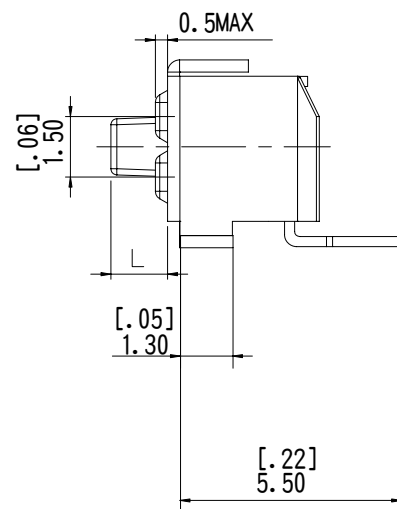
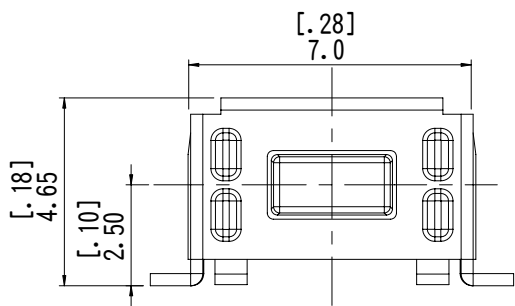
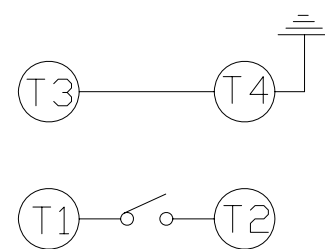

P. C. B. LAYOUT

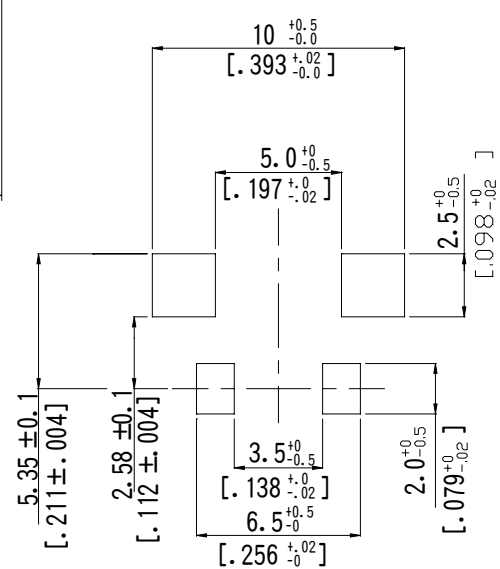
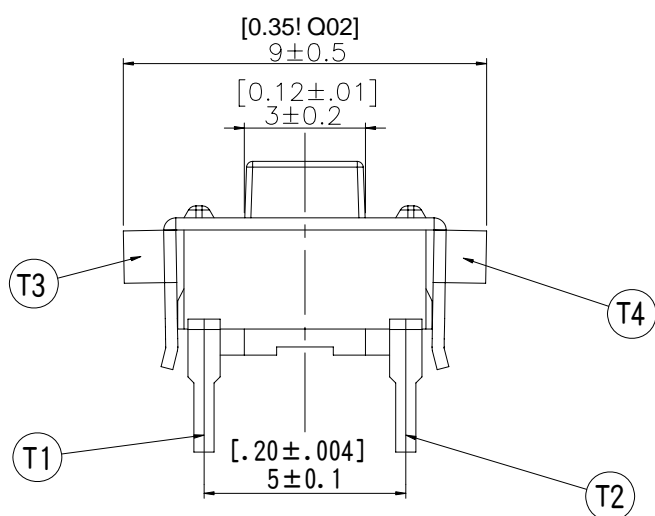

TA2-3

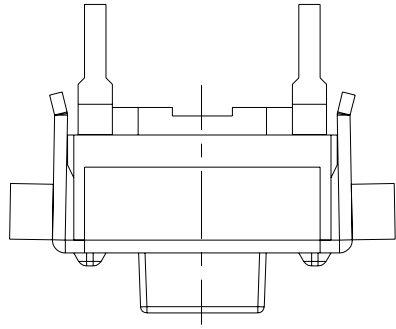

附表一

TA2-32□-V	1.4 [.055]	S	SALMON 320g
		W	WHITE 160g
		N	BROWN 160g
TA2-31□-V	0.7 [.028]	S	SALMON 320g
		W	WHITE 160g
		N	BROWN 160g
PART NAME:	L	COLOR FOR OPERATING FORCE	

CIRCUIT DIAGRAM

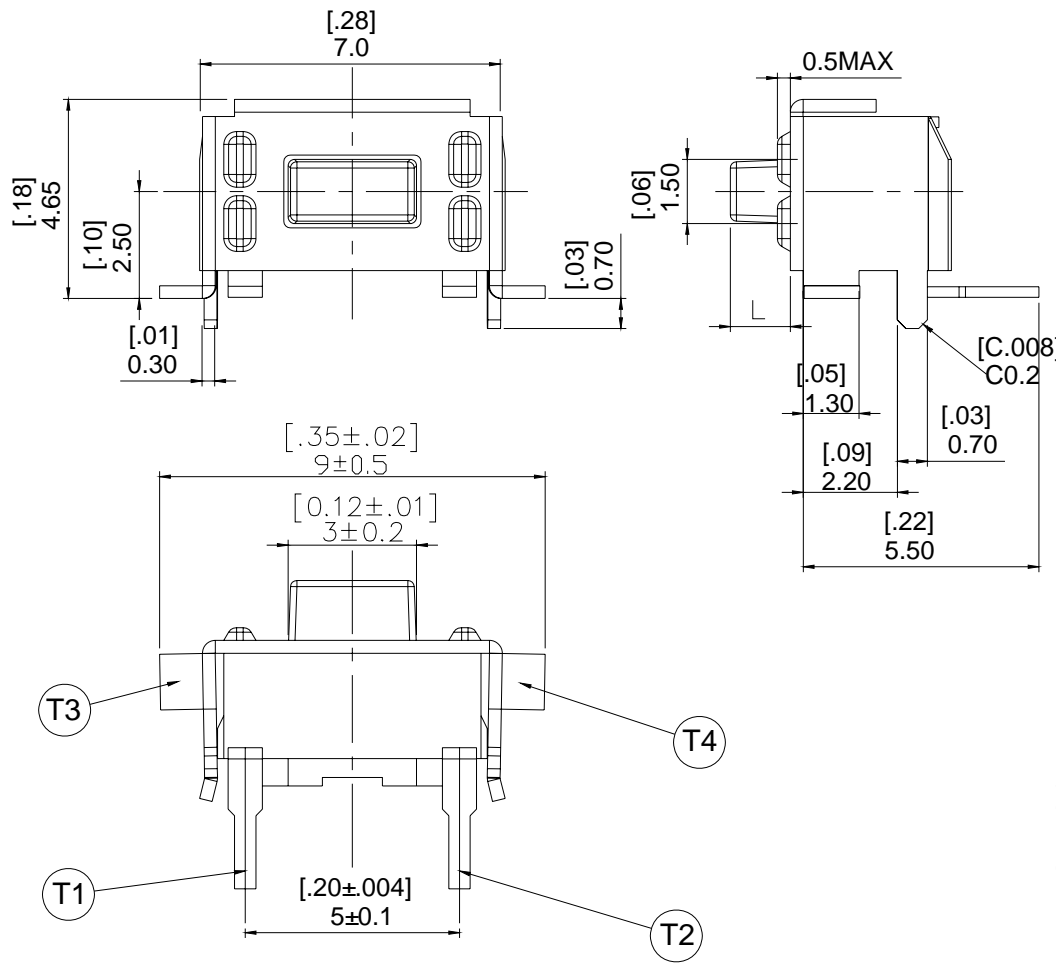
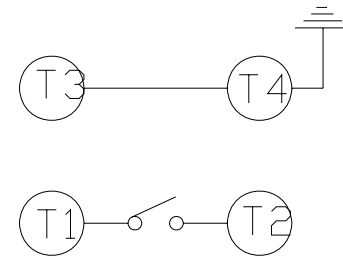

P.C.B. LAYOUT

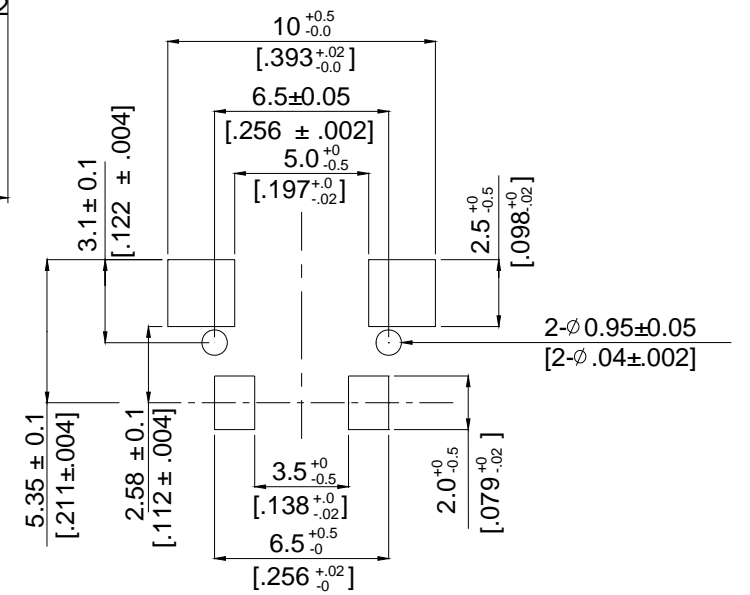

HOW TO ORDER

TA □ □ - □ □ □ - V - □

Package:
T/R=Tape & Reel

Soldering:
V=Lead Free Solderable

Color of Stem for Operating Force:
W=White,160gf
N=Brown,160gf
S=Salmon,320gf

L Height:
1=0.7mm
2=1.4mm

Prod. Size:
3=3.5X6

2=Ground Terminal on both side
C=Ground Terminal in the front

□=With Support Terminal(Only for TA2-3)
N=With support Terminal(Only for TA2-3)

SPECIFICATION

△MECHANICAL

Operation Force: 320±50gf Salmon (S)
160±50gf White (W)

Stroke: 0.25 ^{+0.10mm}/_{-0.20mm}

Operation Temperature: -10°C to +60°C

Storage Temperature: -20°C to +70°C

Vibration Test: MIL-STD-202F METHOD 201A.

Frequency: 10-55-10Hz/1 min.

Directions: X,Y,Z, three mutually perpendicular directions.

Time: 2 hours each direction.

High Reliability.

Shock Test: MIL-STD-202F METHCD 213B.

CONDITION A.

Gravity: 50G(peak value), 11 msec.

Direction and times: 6 sides and 3 times in each direction.

High reliability.

△ELECTRICAL

Electrical Life: 50,000 cycles for 160g, 320g.

Rating: 50mA, 12VDC

Contact Resistance: 100mΩ max.

Insulation Resistance: 100MΩ min. 500V DC

Dielectric Strength: 250VAC / 1 minute

Contact Arrangement 1 pole 1 throw.

MATERIALS

△Cover: Nickel silver.

△BASE: UL94V-0 Nylon High-Thermoplastic.

Color: Black

△CONTACT: Stainless with silver cladding.

△TERMINAL: Brass with silver plated.

△STEM: UL94V-0 Nylon High-Thermoplastic.

Color: Salmon(320gf), Brown(160gf)

SOLDERING PROCESS

△HAND SOLDERING: Use a soldering iron of 30 watts, controlled at 350°C approximately Max 5 seconds while applying.

△REFLOW SOLDERING : When applying reflow soldering, the peak temperature of the reflow oven should be set to 260°C max.

△CONDITION FOR SOLDERING : Reflow & non-washable type

△Temperature Profile :

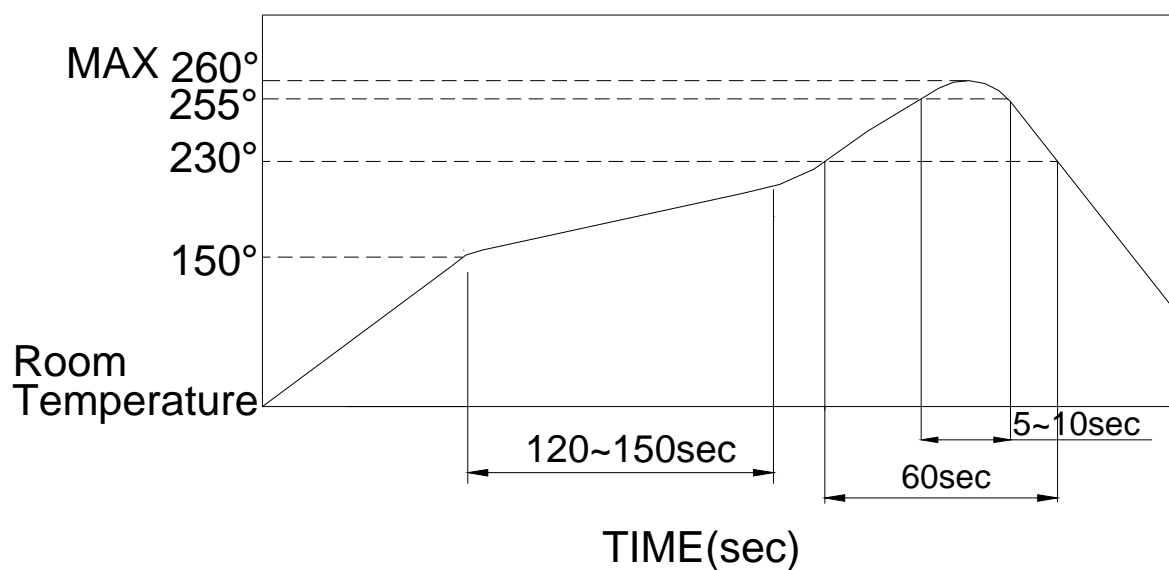

PACKING

Part Number	Number Per Reel	
TAC-3	900	

TAC-3 Reel

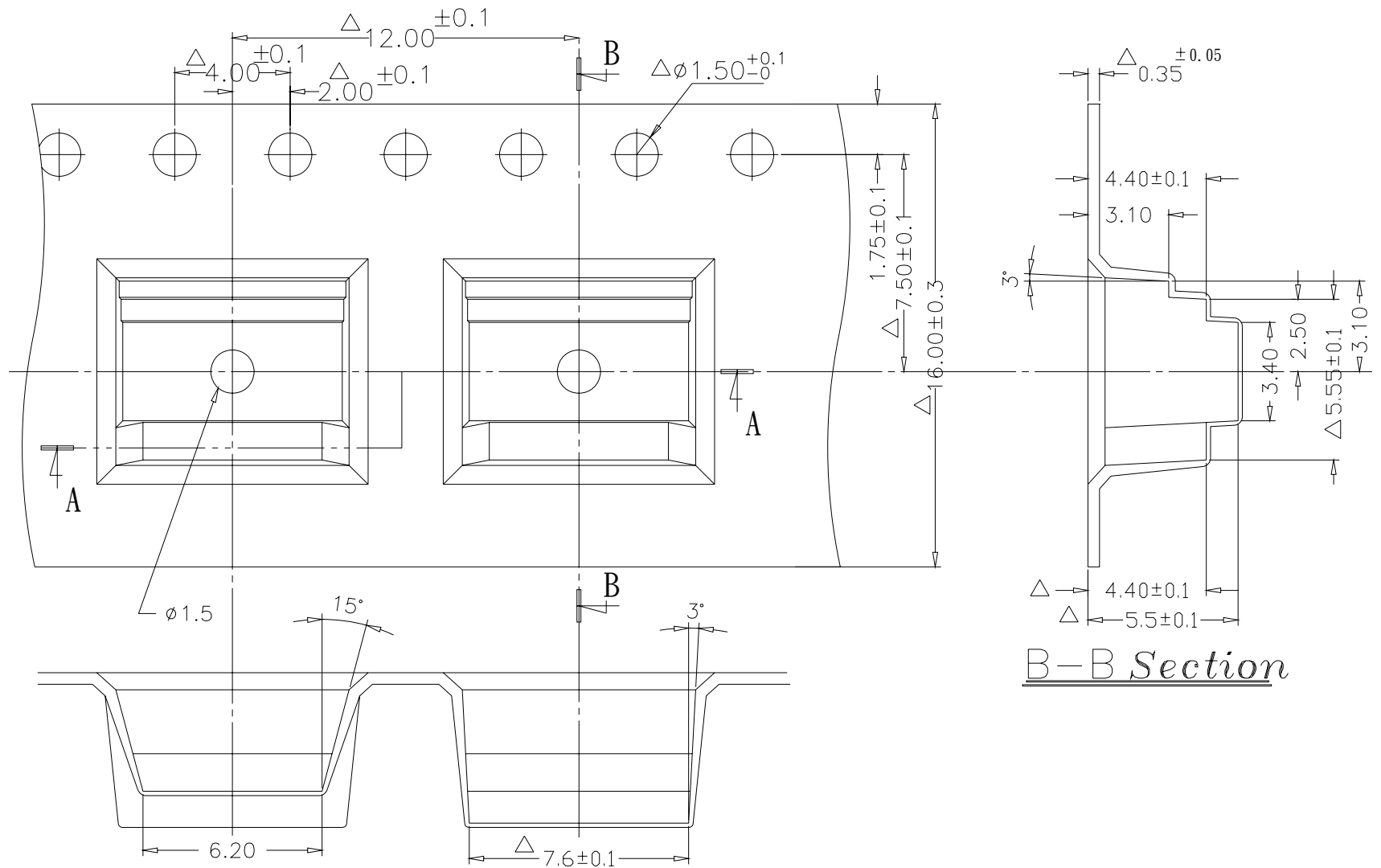

A-A Section

B-B Section



A P E M

Apem Components Ltd
 Drakes Drive, Long Crendon
 Buckinghamshire
 HP18 9BA. U.K

Tel +44 (0)1844 202400 Fax +44 (0)1844 202500