

# KS Series

## Integrated Multiplex System

### Benefits

- CAN BUS
- Increased reliability
- Flexible and expandable system
- Reduced wiring costs

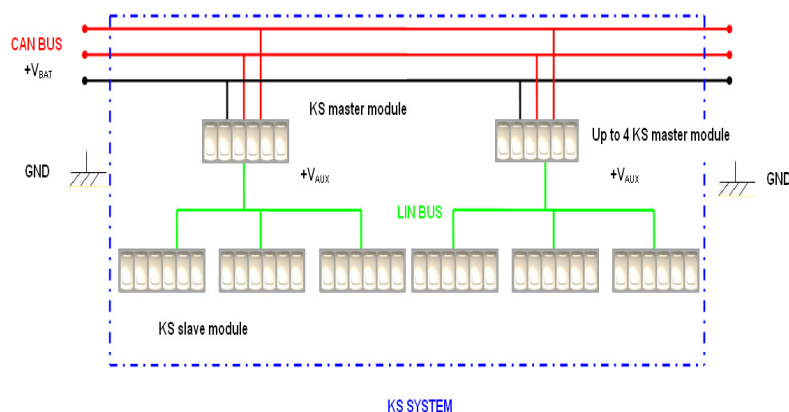

### Applications

- Passengers cars and buses
- Heavy duty vehicles
- Machine control panel
- Boats
- etc.

### Technical Specifications\*

- 12V and 24V power supply
- SAE J1939 Protocol
- Up to 4 master modules
- Up to 3 slave modules supported by master module
- Backlight with LEDs

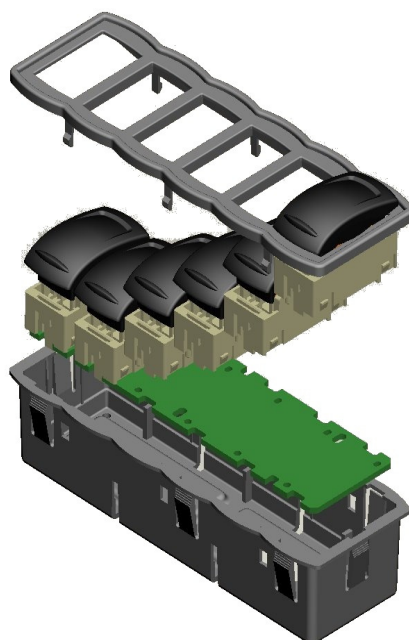

\* Technical brochure on request (23 pages)