

APEM

TW series

Hall effect thumbwheels



The TW Series thumbwheel is a self centering single-axis device developed for thumb-actuated applications requiring proportional output. Utilizing non-contacting Hall effect technology for long life performance, the TW Series thumbwheel delivers up to 5 million thumb actuations. Configuration options include choice of linear voltage outputs as well as wheel colors. The TW Series thumbwheel is available as a stand-alone device or may be incorporated into one of our custom joysticks.



KEY FEATURES

- 5 million cycles**
- Hall effect technology**
- Proportional control**
- Self-centering single-axis design**
- Choice of wheel colors: red, gray, black, or blue**
- EMI/RFI immunity**



TW series

Hall effect thumbwheels

OPTION SELECTION

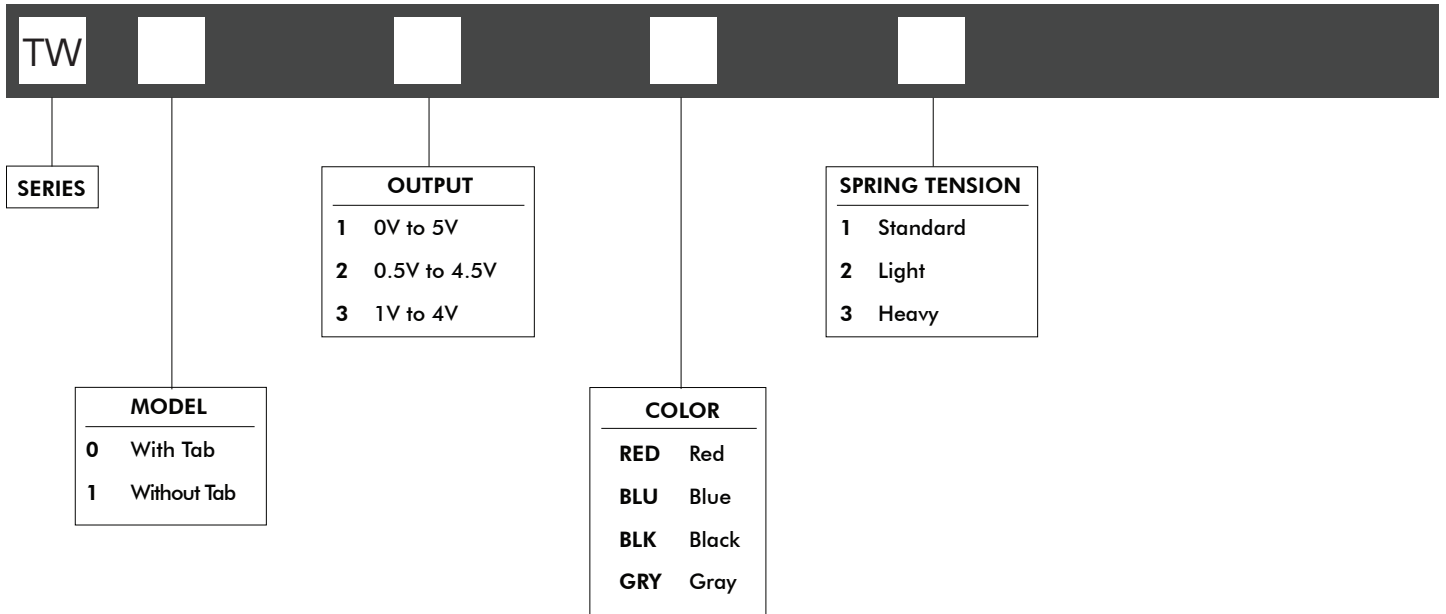

NOTES:



Mounting accessories: steel spring retainer, insertion tool, and sealing gasket.

SPECIFICATIONS

MECHANICAL (FOR X, Y AXES)

Break Out Force	-	0.7N (0.15lbf)
Mechanical Angle of Movement	-	80°
Expected Life	-	5 million cycles
Lever Action (Centering)	-	Spring Centering

ENVIRONMENTAL

Operating Temperature	-	-40°C to +85°C (-40°F to +185°F)
Storage Temperature	-	up to +85°C (+185°F)
Sealing	-	IP67*

ELECTRICAL

Sensor	-	Hall effect
Resolution	-	3.2mV
Supply Voltage Range	-	4.5 - 5.5V
Reverse Polarity Max	-	-16V
Overtoltage Max	-	16V
Output Impedance	-	1.5Ω
Return to Center Voltage (No Load)	-	±40mV
Current Consumption Max	-	8.3mA

NOTES:

- All values are nominal.
- Exact specifications are subject to configuration. Contact Technical Support for the performance of your specific configuration.
- * Electronics sealed to IP67.

TW series

Hall effect thumbwheels

DIMENSIONAL DRAWINGS

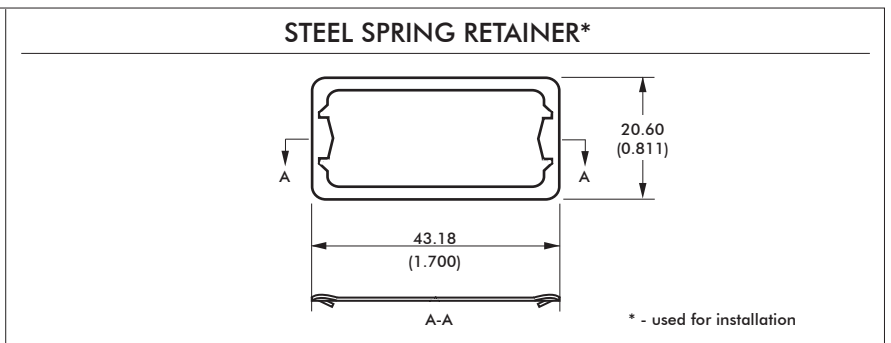
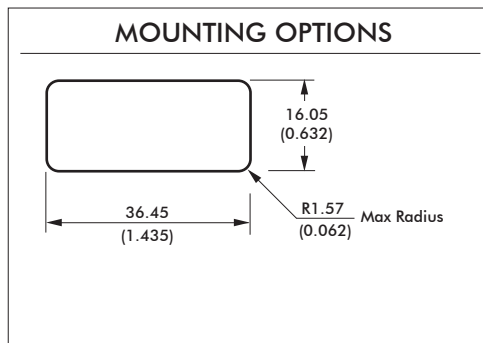
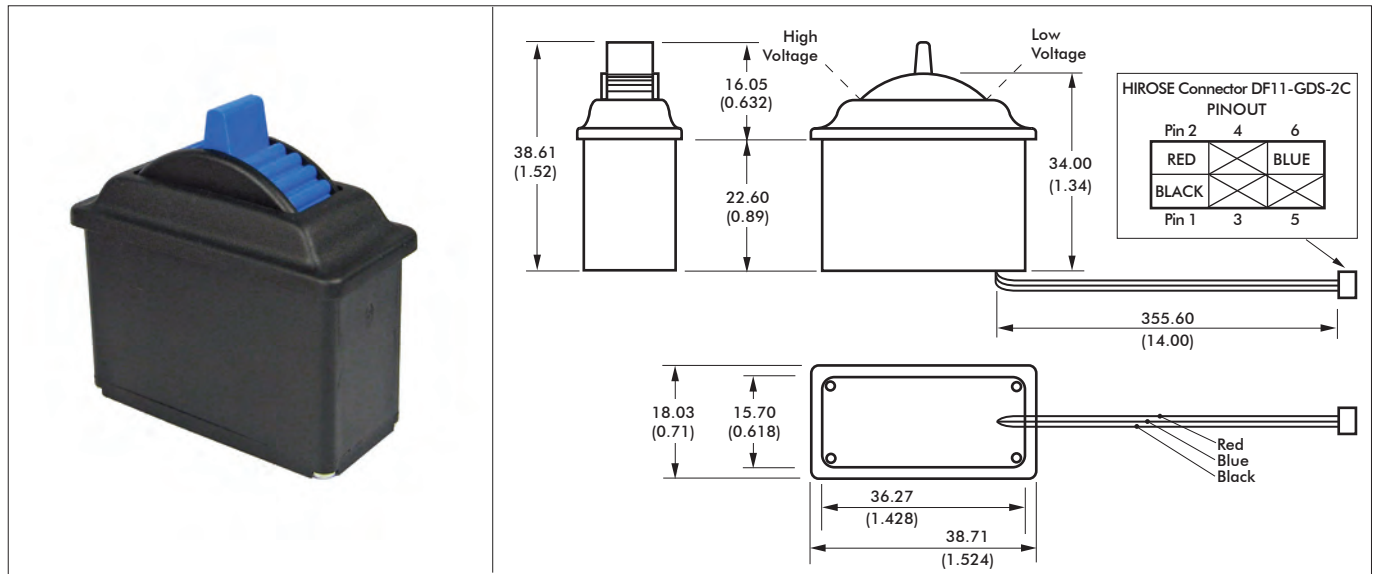

NOTES:

1. Dimensions are in mm/(in)

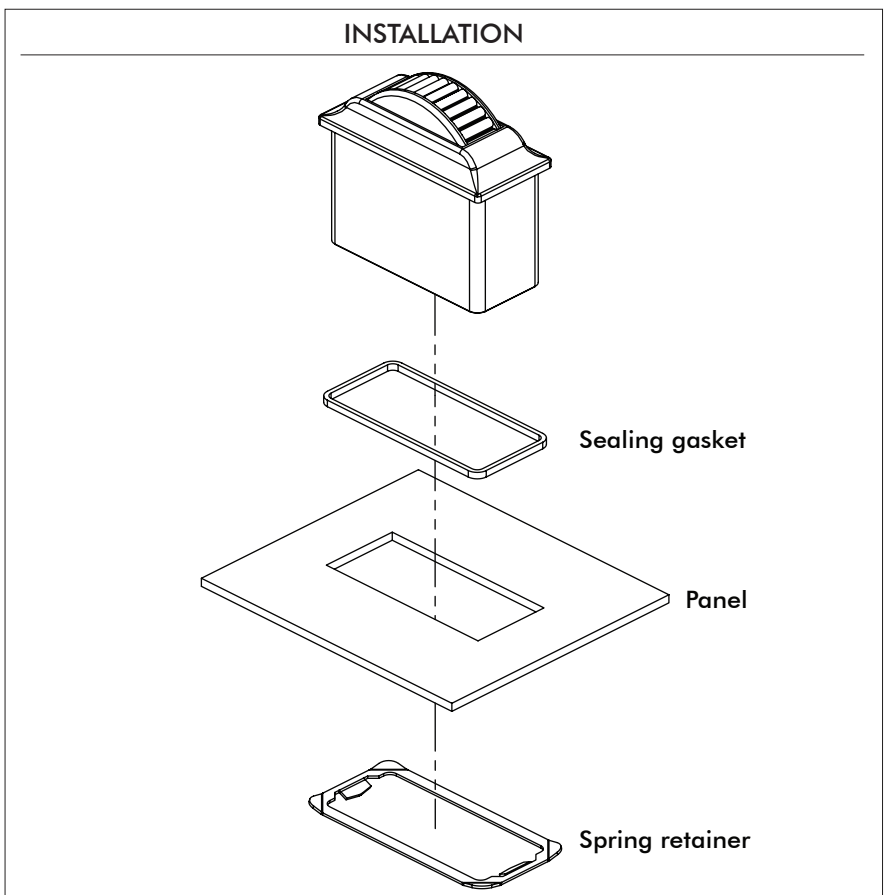

Note: The company reserves the right to change specifications without notice.

TW series

Hall effect thumbwheels

CONFIGURATION OPTIONS

OPTIONS



OPTIONS AVAILABLE: BLACK, RED, BLUE AND GRAY WHEELS WITH OR WITHOUT CENTER TAB.

LINEAR OUTPUT OPTIONS

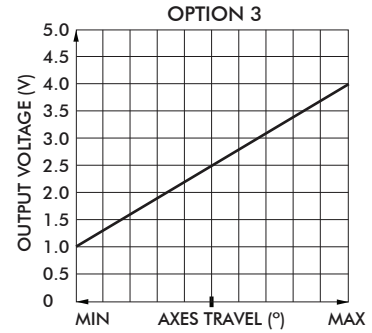
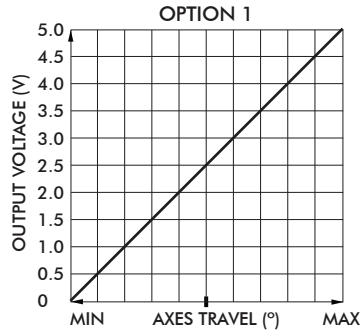

DEFAULT WIRE COLOR CODE

COLOR	FUNCTION	AWG
RED	+5V	28
BLACK	Ground	
BLUE	Output	