

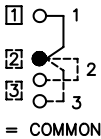
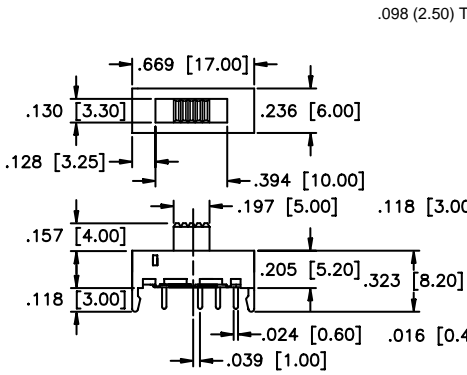
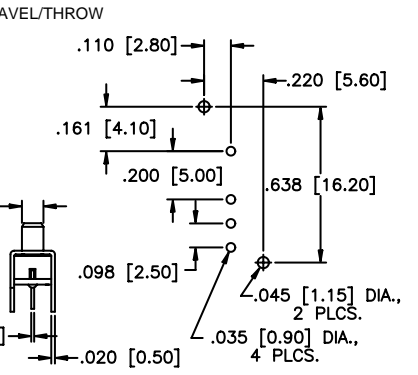

MSTS Series

Miniature Slide Switches

SPECIFICATIONS SUBJECT TO CHANGE WITHOUT NOTICE

SPECIFICATIONS	FEATURES
<p>Contact rating: 300 mA at 28 VDC</p> <p>Initial contact resistance: 20 milliohms max.</p> <p>Insulation resistance: 100 megohms min. at 500 VDC</p> <p>Dielectric strength: 500 VAC for 1 minute</p> <p>Electrical life: 10,000 cycles min.</p> <p>Operating temperature range: -20°C to +85°C</p> <p>Solder heat resistance: 250°C max. for 5 seconds</p> <p>Actuation force: 200-600 grams</p> <p>Solvent washing permissible</p>	<ul style="list-style-type: none"> ● Miniature compact size. ● Wash-through open frame construction. ● Snap-in p.c. mounting bracket design. ● Positive spring loaded ball detent mechanism. ● Epoxy sealed terminals. ● Gold plated contacts available - consult factory.
	MATERIALS
	<p>Contacts & terminals: Silver plated brass</p> <p>Housing: Zinc plated steel</p> <p>Actuator: Polyacetal, color black</p> <p>Base: Phenolic laminated sheet</p> <p style="text-align: right;">Terminal seal: Epoxy</p>

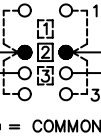
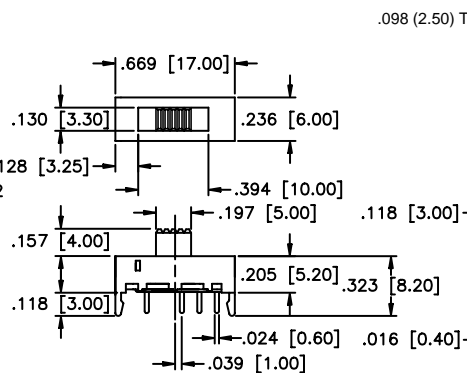
MODEL NO.			
MSTS1332K			
 <p>VERTICAL ACTUATOR</p>	<p>1P3T</p>  <p>SCHMATIC</p>	<p>MECHANICAL OUTLINE</p> 	<p>P.C. BOARD LAYOUT</p> 
MSTS2332K			
 <p>VERTICAL ACTUATOR</p>	<p>2P3T</p>  <p>SCHMATIC</p>	<p>MECHANICAL OUTLINE</p> 	<p>P.C. BOARD LAYOUT</p> 